

# 24" (61 CM) ELECTRIC WASHER/DRYER INSTALLATION INSTRUCTIONS

## Table of Contents

WASHER/DRYER SAFETY .....	1
INSTALLATION REQUIREMENTS.....	3
Tools and Parts.....	3
LOCATION REQUIREMENTS.....	5
DIMENSIONS/CLEARANCES .....	6
DRAIN SYSTEM .....	7
ELECTRICAL REQUIREMENTS .....	8
REMOVE FOAM PACKING.....	9
INSTALL LEVELING LEGS.....	9
ELECTRICAL CONNECTION .....	10
VENTING.....	15
Venting Requirements.....	15
Plan Vent System.....	16
Install Vent System.....	17
CONNECT DRAIN HOSE.....	18
CONNECT INLET HOSES.....	19
CONNECT VENT .....	20
LEVEL WASHER/DRYER.....	21
COMPLETE INSTALLATION CHECKLIST .....	22

## INSTALLATION NOTES

Date of purchase: \_\_\_\_\_  
Date of installation: \_\_\_\_\_  
Installer: \_\_\_\_\_  
Model number: \_\_\_\_\_  
Serial number: \_\_\_\_\_

## WASHER/DRYER SAFETY

### Your safety and the safety of others are very important.

We have provided many important safety messages in this manual and on your appliance. Always read and obey all safety messages.



This is the safety alert symbol.

This symbol alerts you to potential hazards that can kill or hurt you and others.

All safety messages will follow the safety alert symbol and either the word "DANGER" or "WARNING."

These words mean:

**⚠ DANGER**

You can be killed or seriously injured if you don't immediately follow instructions.

**⚠ WARNING**

You can be killed or seriously injured if you don't follow instructions.

All safety messages will tell you what the potential hazard is, tell you how to reduce the chance of injury, and tell you what can happen if the instructions are not followed.

# WASHER/DRYER SAFETY



## **WARNING - “Risk of Fire”**

- Clothes dryer installation must be performed by a qualified installer.
- Install the clothes dryer according to the manufacturer’s instructions and local codes.
- Do not install a clothes dryer with flexible plastic venting materials or flexible metal (foil type) duct. If flexible metal duct is installed, it must be of a specific type identified by the appliance manufacturer as suitable for use with clothes dryers. Flexible venting materials are known to collapse, be easily crushed, and trap lint. These conditions will obstruct clothes dryer airflow and increase the risk of fire.
- To reduce the risk of severe injury or death, follow all installation instructions.
- Save these instructions.

### IMPORTANT SAFETY INSTRUCTIONS

**WARNING:** To reduce the risk of fire, electric shock, or injury to persons when using the washer/dryer, follow basic precautions, including the following:

- Read all instructions before using the washer/dryer.
- Do not place items exposed to cooking oils in your dryer. Items contaminated with cooking oils may contribute to a chemical reaction that could cause a load to catch fire.
- Do not wash or dry articles that have been previously cleaned in, washed in, soaked in, or spotted with gasoline, dry-cleaning solvents, other flammable, or explosive substances as they give off vapors that could ignite or explode.
- Do not add gasoline, dry-cleaning solvents, or other flammable, or explosive substances to the wash water. These substances give off vapors that could ignite or explode.
- Do not allow children to play on or in the washer/dryer. Close supervision of children is necessary when the washer/dryer is used near children.
- Before the washer/dryer is removed from service or discarded, remove the doors to the washer/dryer compartments.
- Do not reach into the washer/dryer if the tub, agitator or drum is moving.
- Do not install or store the washer/dryer where it will be exposed to the weather.
- Do not tamper with controls.
- Clean dryer lint screen before or after each load.
- Under certain conditions, hydrogen gas may be produced in a hot water system that has not been used for 2 weeks or more. **HYDROGEN GAS IS EXPLOSIVE.** If the hot water system has not been used for such a period, before using the washing machine, turn on all hot water faucets and let the water flow from each for several minutes. This will release any accumulated hydrogen gas. As the gas is flammable, do not smoke or use an open flame during this time.
- Do not repair or replace any part of the washer/dryer or attempt any servicing unless specifically recommended in this Use and Care Guide or in published user-repair instructions that you understand and have the skills to carry out.
- Do not use fabric softeners or products to eliminate static unless recommended by the manufacturer of the fabric softener or product.
- Do not use heat to dry articles containing foam rubber or similarly textured rubber-like materials.
- Keep area around the exhaust opening and adjacent surrounding areas free from the accumulation of lint, dust, and dirt.
- The interior of the machine and dryer exhaust vent should be cleaned periodically by qualified service personnel.
- See “Electrical Requirements” section of the Installation Instructions booklet for grounding instructions.

**SAVE THESE INSTRUCTIONS**

# INSTALLATION REQUIREMENTS

## TOOLS AND PARTS

Gather required tools and parts before starting installation.

### Tools needed:

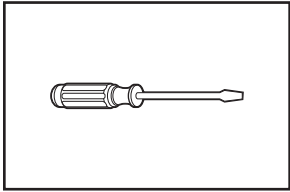

Flat-blade screwdriver

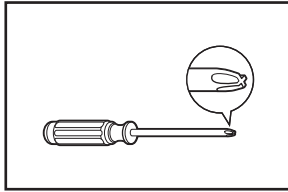

#2 Phillips screwdriver

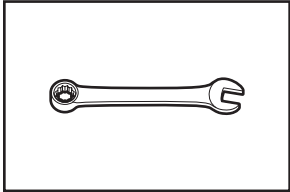

Adjustable or open-end wrench 9/16" (14 mm)

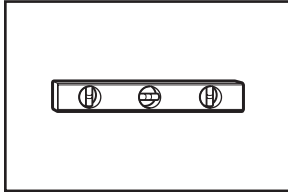

Level

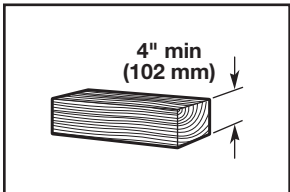

Wood block

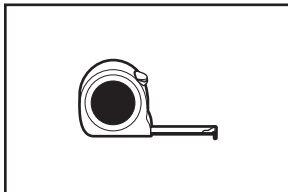

Ruler or measuring tape

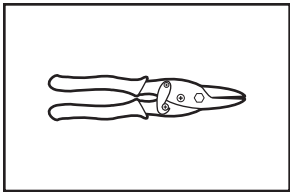

Tin snips (new vent installations)

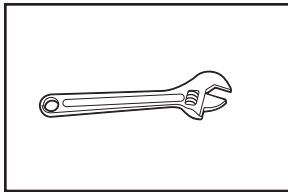

Adjustable wrench that opens to 1" (25 mm) or hex-head socket wrench

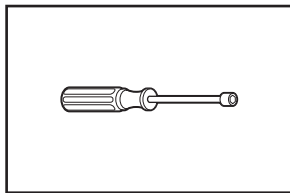

1/4" nut driver (recommended)

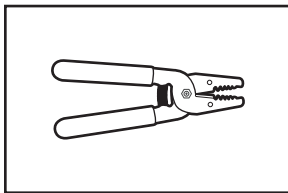

Wire stripper

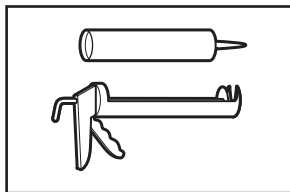

Caulking gun and compound (new vent installations)

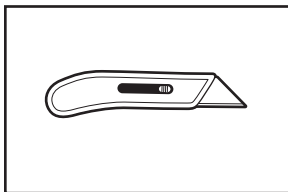

Utility knife

### Optional tools:

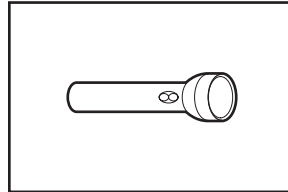

Flashlight

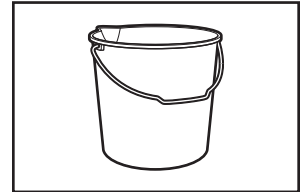

Bucket

### Parts supplied:

**NOTE:** Remove parts package from the washer basket. Check that all parts were included.

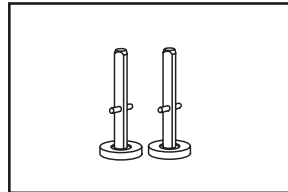

Rear leveling legs with nuts (2)

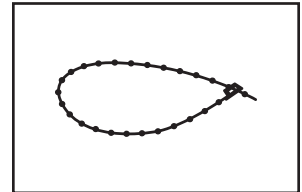

Removable tie strap

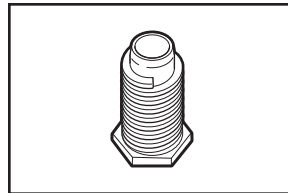

Front leveling legs with nuts (2)

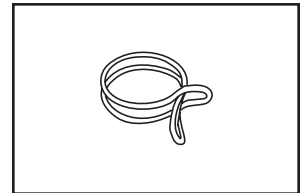

Silver double-wire hose clamp

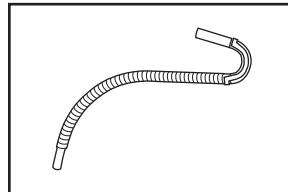

Drain hose

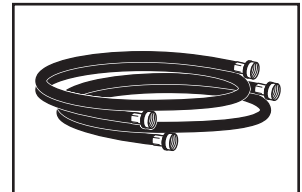

Inlet hoses with flat washers

# INSTALLATION REQUIREMENTS

## TOOLS AND PARTS

### Parts needed: (Not supplied with washer/dryer)

- Vent clamps
- Vent elbows and ductwork

Check local codes, electrical supply and venting, and read “Electrical Requirements” and “Venting Requirements” before purchasing parts. Mobile home installations require metal exhaust system hardware available for purchase from the dealer from whom you purchased your washer/dryer. For further information, please reference the “Assistance or Service” section of the Washer/Dryer Use and Care Guide.

### Optional equipment: (Not supplied with washer/dryer)

Refer to your Use and Care Guide for information about accessories available for your washer/dryer.

### Alternate parts: (Not supplied with washer/dryer)

Your installation may require additional parts. To order, please refer to toll-free numbers on back page of your Use and Care Guide.

#### If you have:

Overhead sewer

Floor drain

1" (25 mm) standpipe

Laundry tub or standpipe taller than 96" (2.4 m)

Drain hose too short

Lint clogged drain

Water faucets beyond reach of fill hoses

#### You will need:

Standard 20 gal. (76 L) 39" (990 mm) tall Drain Tub or Utility Sink, Sump Pump and Connectors (available from local plumbing suppliers)

Siphon Break Part Number 285320, Additional Drain Hose Part Number 285702, and Connector Kit Part Number 285442

2" (51 mm) diameter to 1" (25 mm) diameter Standpipe Adapter Part Number 3363920, Connector Kit Part Number 285835

Sump pump system (if not already available)

Extension Drain Hose Part Number 285664, Connector Kit Part Number 285442

Drain Protector Part Number 367031, Connector Kit Part Number 285835

2 longer water fill hoses:  
6 ft (1.8 m) Part Number 76314,  
10 ft (3.0 m) Part Number 350008

# LOCATION REQUIREMENTS

**⚠ WARNING**



**Explosion Hazard**  
**Keep flammable materials and vapors, such as gasoline, away from dryer.**  
**Do not install in a garage.**  
**Failure to do so can result in death, explosion, or fire.**

Select proper location for your washer to improve performance and minimize noise and possible “washer walk.” Install your washer in a basement, laundry room, closet, or recessed area.

## You will need:

- A location that allows for proper exhaust installation. See “Venting Requirements.”
- A separate 30-amp circuit.
- If you are using a power supply cord, a grounded electrical outlet located within 2 ft (610 mm) of either side of the washer/dryer. See “Electrical Requirements.”
- A sturdy floor to support the washer/dryer weight (washer/dryer, water, and load) of 500 lbs (226.8 kg).
- A level floor with a maximum slope of 1" (25 mm) under entire washer/dryer. Clothes may not tumble properly and automatic sensor cycles may not operate correctly if washer/dryer is not level. Installing on carpet is not recommended.
- A water heater set to deliver 120°F (49°C) water to the washer.
- Hot and cold water faucets located within 4 ft (1.2 m) of the hot and cold water fill valves, and water pressure of 5–100 psi (34.5–689.6 kPa).

The washer/dryer must not be installed or stored in an area where it will be exposed to water and/or weather.

Do not operate your washer in temperatures at or below 32°F (0°C). Some water can remain in the washer and can cause damage in low temperatures. See “Washer/Dryer Care” in the Washer/Dryer Use and Care Guide for winterizing information.

Do not operate your dryer at temperatures below 45°F (7°C). At lower temperatures, the dryer might not shut off at the end of an automatic cycle. This can result in longer drying times.

Check code requirements. Some codes limit, or do not permit, installation of the washer/dryer in garages, closets, mobile homes, or sleeping quarters. Contact your local building inspector.

## Recessed area or closet installation

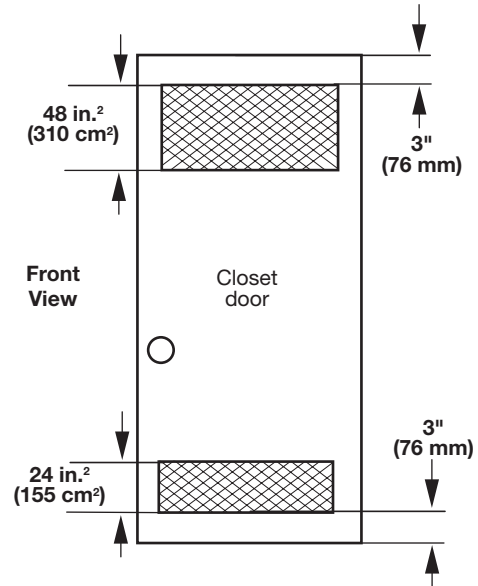

The spacing dimensions above are recommended for this washer/dryer. This washer/dryer has been tested for spacing of 0" (0 mm) clearance on the sides. Recommended spacing should be considered for the following reasons:

- Additional spacing should be considered for ease of installation and servicing.
- Additional clearances might be required for wall, door, and floor moldings.
- Additional spacing on all sides of the washer/dryer is recommended to reduce noise transfer.
- For closet installation, with a door, minimum ventilation openings in the top and bottom of the door are required. Louvered doors with equivalent ventilation openings are acceptable.

## Mobile Home – Additional Installation Requirements

This washer/dryer is suitable for mobile home installations. The installation must conform to the Manufactured Home Construction and Safety Standard, Title 24 CFR, Part 3280 (formerly the Federal Standard for Mobile Home Construction and Safety, Title 24, HUD Part 280).

### Mobile home installations require:

- Metal exhaust system hardware, which is available for purchase from your dealer.
- Special provisions must be made in mobile homes to introduce outside air into the dryer. The opening (such as a nearby window) should be at least twice as large as the dryer exhaust opening.

# DIMENSIONS/CLEARANCES

## Dimensions

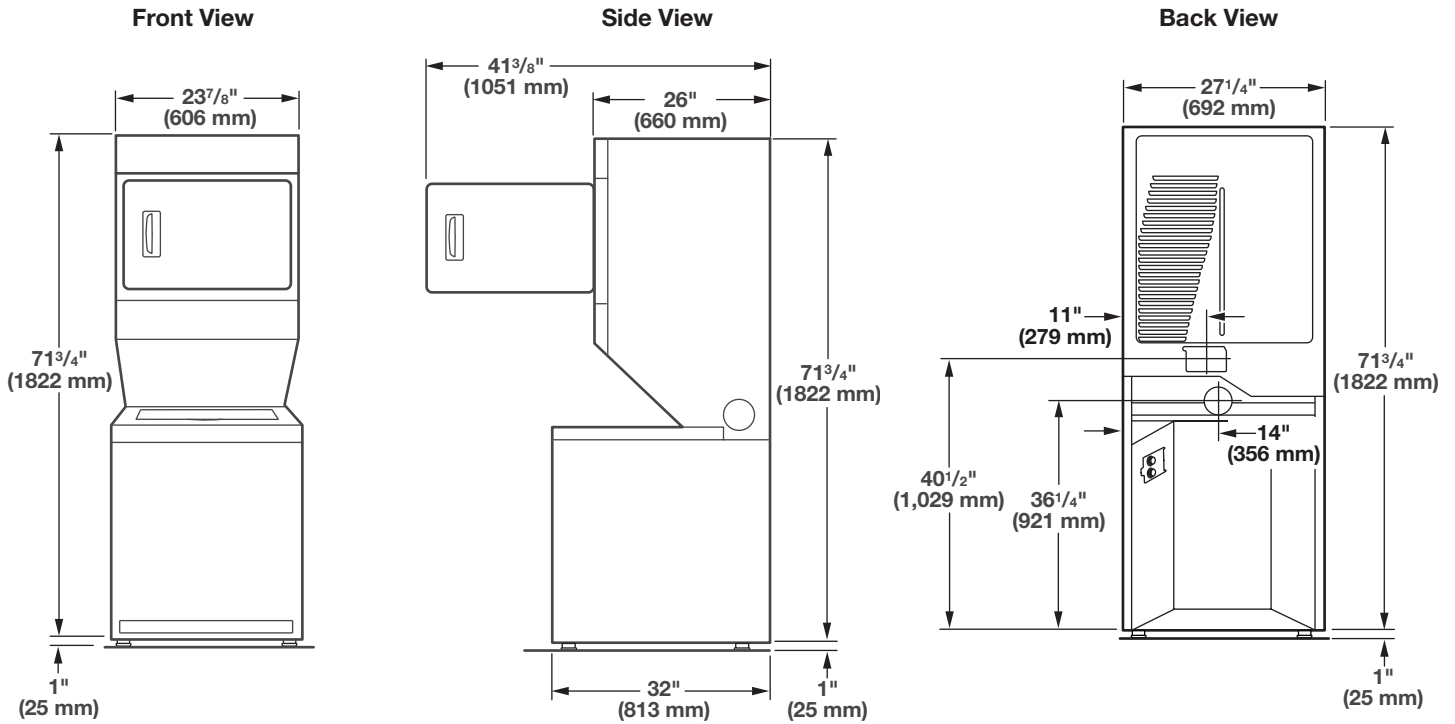

## Clearances

### Side Clearances (recommended/minimum)

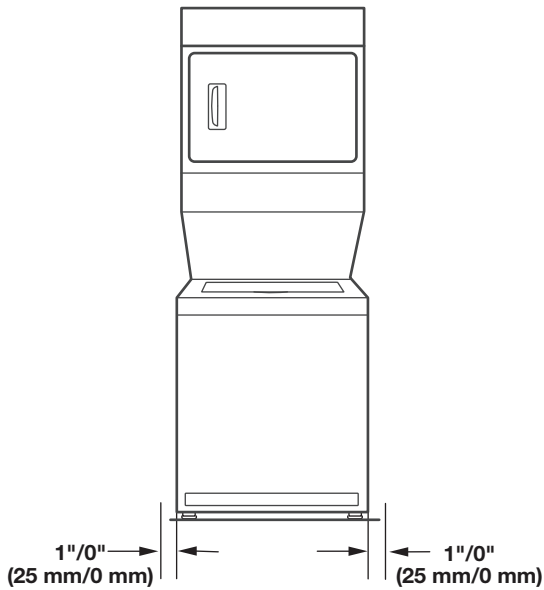

### Front/Back/Top Clearances

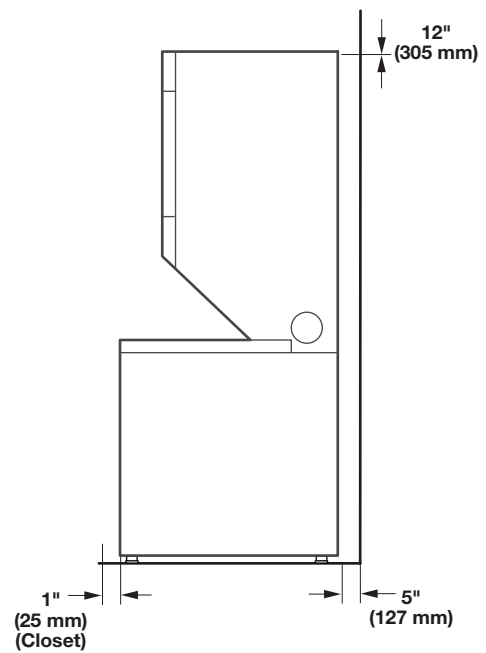

# DRAIN SYSTEM

Drain system can be installed using a floor drain, wall standpipe, or laundry tub. Select method you need.

## Floor standpipe drain system

Minimum diameter for a standpipe drain: 2" (51 mm). Minimum carry-away capacity: 17 gal. (64 L) per minute. Top of standpipe must be at least 39" (991 mm) high; install no higher than 96" (2.4 m) from bottom of washer/dryer. If you must install higher than 96" (2.4 m), you will need a sump pump system.

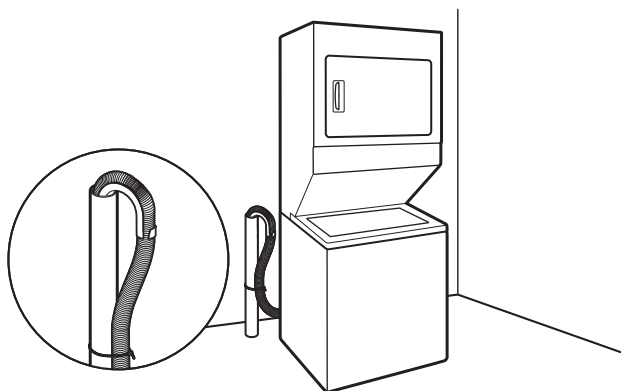

## Wall standpipe drain system

See requirements for floor standpipe drain system.

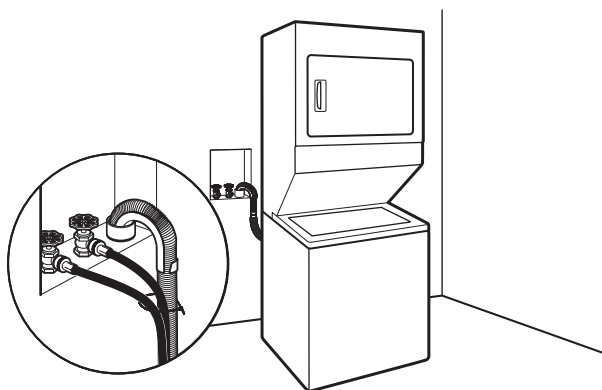

## Floor drain system

Floor drain system requires a Siphon Break Kit (Part Number 285834), 2 Connector Kits (Part Number 285385), and an Extension Drain Hose (Part Number 285863) that may be purchased separately. To order, please see toll-free phone numbers in your Use and Care Guide. Minimum siphon break: 28" (710 mm) from bottom of washer/dryer. (Additional hoses may be needed.)

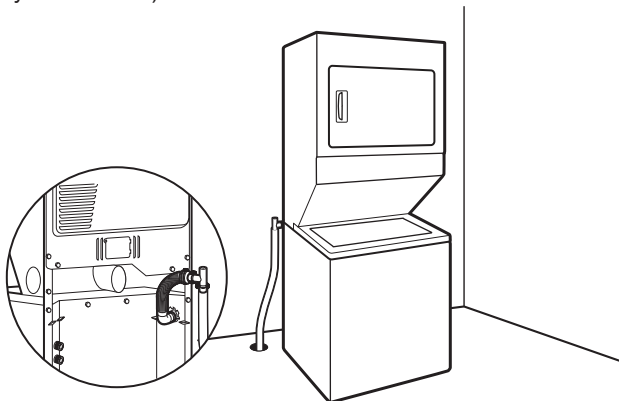

## Laundry tub drain system

Minimum capacity: 20 gal. (76 L). Top of laundry tub must be at least 39" (991 mm) above floor; install no higher than 96" (2.4 m) from bottom of washer/dryer.

**IMPORTANT:** To avoid siphoning, no more than 4.5" (114 mm) of drain hose should be inside standpipe or below the top of wash tub. Secure drain hose with tie strap.

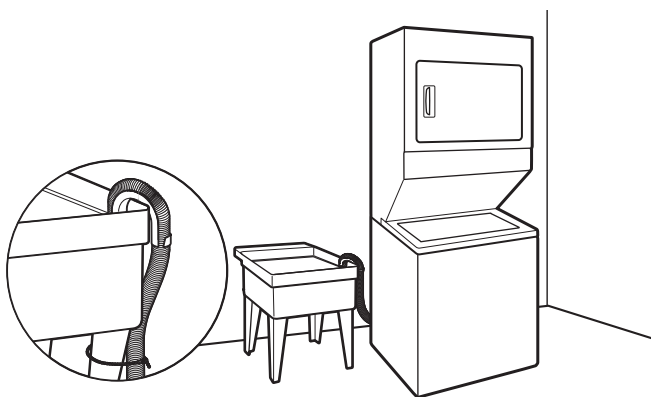



# ELECTRICAL REQUIREMENTS

## ⚠ WARNING



### Electrical Shock Hazard

**Plug into a grounded 3 or 4 prong outlet.**

**Do not remove ground prong.**

**Do not use an adapter.**

**Do not use an extension cord.**

**Failure to follow these instructions can result in death, fire, or electrical shock.**

- It is recommended that a separate circuit breaker serving only this appliance be provided.
- To minimize possible shock hazard, the cord must be plugged into a mating, 3- or 4-prong, grounding-type outlet, grounded in accordance with local codes and ordinances. If a mating outlet is not available, it is the personal responsibility and obligation of the customer to have the properly grounded outlet installed by a qualified electrician.
- If codes permit and a separate ground wire is used, it is recommended that a qualified electrician determine that the ground path is adequate.
- Check with a qualified electrician if you are not sure the washer is properly grounded.
- Do not have a fuse in the neutral or ground circuit.

### It is your responsibility:

- To contact a qualified electrical installer.
- To be sure that the electrical connection is adequate and in conformance with the National Electrical Code, ANSI/NFPA 70-latest edition and all local codes and ordinances.  
A copy of the above code standards can be obtained from: National Fire Protection Association, One Batterymarch Park, Quincy, MA 02269.
- To supply the required 3- or 4-wire, single phase, 120/240 volt, 60 Hz., AC only electrical supply (or 3- or 4-wire, 120/208 volt electrical supply, if specified on the serial/rating plate) on a separate 30-amp circuit, fused on both sides of the line. A time-delay fuse or circuit breaker is recommended. Connect to an individual branch circuit.
- Do not use an extension cord.

### Electrical Connection

To properly install your washer/dryer, you must determine the type of electrical connection you will be using and follow the instructions provided for it here.

- This washer/dryer is manufactured ready to install with a 3-wire electrical supply connection. The neutral ground wire is permanently connected to the neutral conductor (white wire) within the dryer. If the dryer is installed with a 4-wire electrical supply connection, the neutral ground wire must be removed from the internal ground connector (green screw), and secured under the neutral terminal (center or white wire) of the terminal block. When the neutral ground wire is secured under the neutral terminal (center or white wire) of the terminal block, the dryer cabinet is isolated from the neutral conductor.
- If local codes do not permit the connection of a neutral ground wire to the neutral wire, see “Optional 3-wire connection” in the “Electrical Connection” section.
- A 4-wire power supply connection must be used when the appliance is installed in a location where grounding through the neutral conductor is prohibited. Grounding through the neutral is prohibited for (1) new branch-circuit installations, (2) mobile homes, (3) recreational vehicles, and (4) areas where local codes prohibit grounding through the neutral conductors.

### If using a power supply cord:

Use a UL listed power supply cord kit marked for use with clothes dryers. The kit should contain:

- A UL listed 30-amp power supply cord, rated 120/240 volt minimum. The cord should be type SRD or SRDT and be at least 4 ft (1.22 m) long. The wires that connect to the dryer must end in ring terminals or spade terminals with upturned ends.
- A UL-listed strain relief.

### If your outlet looks like this:



4-wire  
receptacle  
(14-30R)

Then choose a 4-wire power supply cord with ring or spade terminals and UL-listed strain relief. The 4-wire power supply cord, at least 4 ft (1.22 m) long, must have four 10-gauge copper wires and match a 4-wire receptacle of NEMA Type 14-30R. The ground wire (ground conductor) may be either green or bare. The neutral conductor must be identified by a white cover.

### If your outlet looks like this:



3-wire  
receptacle  
(10-30R)

Then choose a 3-wire power supply cord with ring or spade terminals and UL-listed strain relief. The 3-wire power supply cord, at least 4 ft (1.22 m) long, must have three 10-gauge copper wires and match a 3-wire receptacle of NEMA Type 10-30R.

### If connecting by direct wire:

Power supply cable must match power supply (4-wire or 3-wire) and be:

- Flexible armored cable or nonmetallic sheathed copper cable (with ground wire), covered with flexible metallic conduit. All current-carrying wires must be insulated.
- 10-gauge solid copper wire (do not use aluminum).
- At least 5 ft (1.52 m) long.



# ELECTRICAL REQUIREMENTS

## GROUNDING INSTRUCTIONS

### For a grounded, cord-connected washer/dryer:

This washer/dryer must be grounded. In the event of a malfunction or breakdown, grounding will reduce the risk of electrical shock by providing a path of least resistance for electric current. This washer/dryer is equipped with a cord having an equipment-grounding conductor and a grounding plug. The plug must be plugged into an appropriate outlet that is properly installed and grounded in accordance with all local codes and ordinances.

**WARNING:** Improper connection of the equipment-grounding conductor can result in a risk of electric shock. Check with a qualified electrician or serviceman if you are in doubt as to whether the appliance is properly grounded.

Do not modify the plug provided with the appliance – if it will not fit the outlet, have a proper outlet installed by a qualified electrician.

### For a permanently connected washer/dryer:

This washer/dryer must be connected to a grounded metal, permanent wiring system, or an equipment grounding conductor must be run with the circuit conductors and connected to the equipment-grounding terminal or lead on the appliance.

**SAVE THESE INSTRUCTIONS**

# INSTALL LEVELING LEGS

## ⚠ WARNING

### Excessive Weight Hazard

**Use two or more people to move and install washer/dryer.**

**Failure to do so can result in back or other injury.**

To avoid floor damage, set washer/dryer onto cardboard before moving across floor. Move washer/dryer close to its final location. Gently place the washer/dryer on its side, on the cardboard.

## 1. Install rear leveling legs

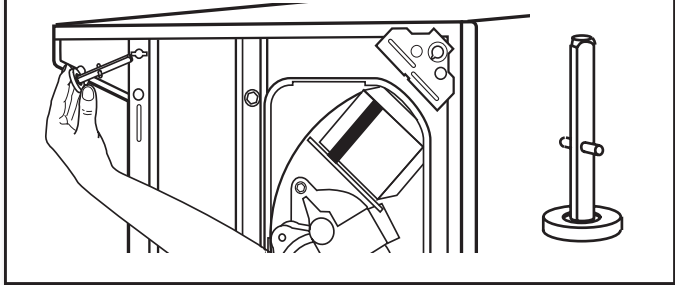

Push legs into holes in rear corners until they snap into place. Check adjustability of rear legs by pushing in one leg. The other leg should come out. Check both legs. If they do not move freely, remove legs and repeat this step.

# REMOVE FOAM PACKING

## 1. Open washer lid and pull out foam packing ring

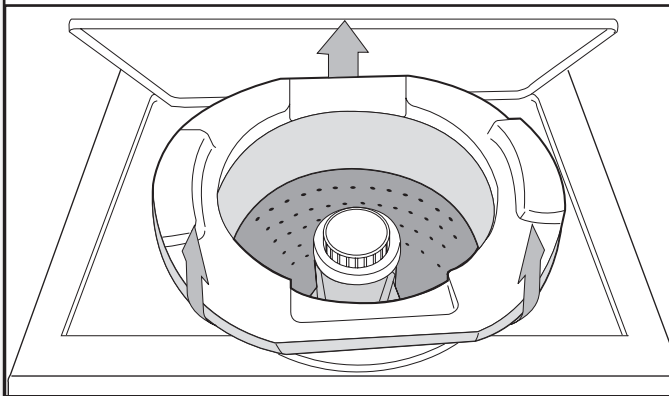

The latch under the dryer will keep the lid open. Keep the foam ring and use it when transporting your washer/dryer. This packing material is used to keep the washer drum stable during transport.

## 2. Install front leveling legs

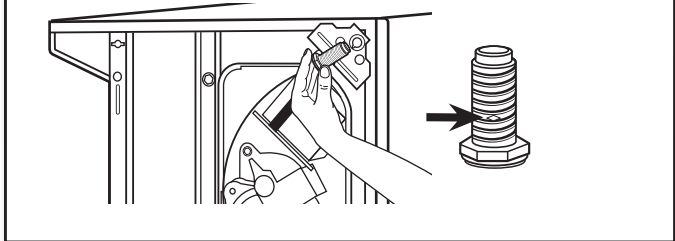

Examine the front leveling legs. Find the diamond marking. Screw front legs by hand into the holes in the triangular braces in the front corners. Use wrench to finish turning the legs until the diamond marking is no longer visible. Slowly stand the washer/dryer upright.

# ELECTRICAL CONNECTION

## Power Supply Cord

### ⚠ WARNING



#### Fire Hazard

- Use a new UL listed 30 amp power supply cord.
- Use a UL listed strain relief.
- Disconnect power before making electrical connections.
- Connect neutral wire (white or center wire) to center terminal.
- Ground wire (green or bare wire) must be connected to green ground connector.
- Connect remaining 2 supply wires to remaining 2 terminals (gold).
- Securely tighten all electrical connections.
- Failure to do so can result in death, fire, or electrical shock.

## Direct Wire

### ⚠ WARNING



#### Fire Hazard

- Use 10 gauge copper wire.
- Use a UL listed strain relief.
- Disconnect power before making electrical connections.
- Connect neutral wire (white or center wire) to center terminal.
- Ground wire (green or bare wire) must be connected to green ground connector.
- Connect remaining 2 supply wires to remaining 2 terminals (gold).
- Securely tighten all electrical connections.
- Failure to do so can result in death, fire, or electrical shock.

## Electrical Connection Options

### 1. Choose electrical connection type



Power supply cord 4-wire receptacle (NEMA Type 14-30R): Go to “4-wire Power Supply Cord Connection” section. Then, go to “Venting Requirements.”



Power supply cord 3-wire receptacle (NEMA Type 10-30R): Go to “3-wire Power Supply Cord Connection” section. Then go to “Venting Requirements.”



4-wire direct connection: Go to “4-wire Direct Wire Connection” section. Then go to “Venting Requirements.”



3-wire direct connection: Go to “3-wire Direct Wire Connection” section. Then go to “Venting Requirements.”

**NOTE:** If local codes do not permit connection of a cabinet-ground conductor to neutral wire, go to “Optional 3-wire Connection” section. This connection may be used with either a power supply cord or a direct wire connection.

### 2. Remove terminal block cover

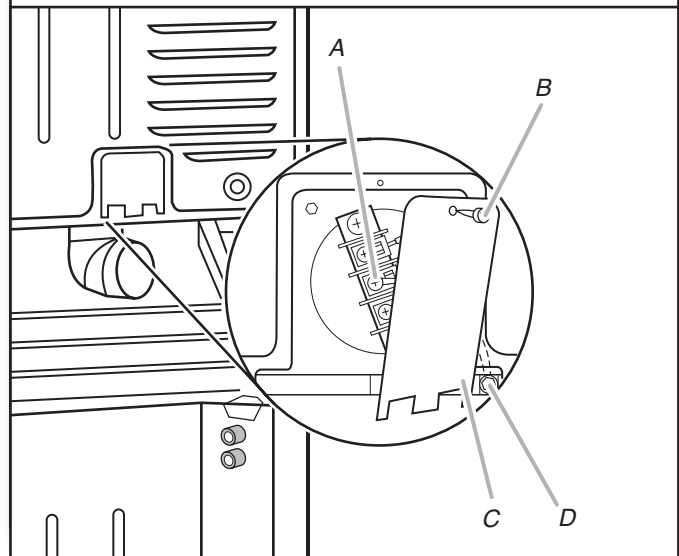

Before you start, disconnect power. Remove hold-down screw (B) and terminal block cover (C). Install strain relief.

- A. Center terminal block screw
- B. Hold-down screw
- C. Terminal block cover
- D. External ground conductor screw

# Power Supply Cord Connection

## Power Supply Cord Strain Relief

### 1. Attach power supply cord strain relief

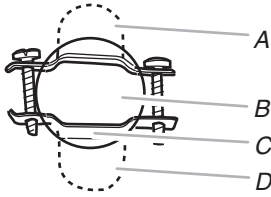

Remove the screws from a 3/4" (19 mm) UL-listed strain relief (UL marking on strain relief). Put the tabs of the two clamp sections (C) into the hole below the terminal block opening (B) so that one tab is pointing up (A) and the other is pointing down (D), and hold in place. Tighten strain relief screws just enough to hold the two clamp sections (C) together.

### 2. Attach power supply cord to strain relief

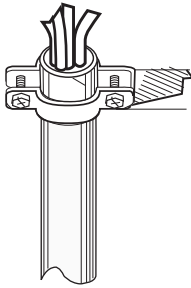

Put power supply cord through the strain relief. Be sure that the wire insulation on the power supply cord is inside the strain relief. The strain relief should have a tight fit with the dryer cabinet and be in a horizontal position. Do not further tighten strain relief screws at this point.

If your outlet looks like this:



Power supply cord 4-wire receptacle (NEMA Type 14-30R):  
Go to "4-Wire Power Supply Cord Connection" on this page.



Power supply cord 3-wire receptacle (NEMA Type 10-30R):  
Go to "3-Wire Power Supply Cord Connection" on page 12.

# 4-Wire Power Supply Cord Connection

**IMPORTANT:** A 4-wire connection is required for mobile homes and where local codes do not permit the use of 3-wire connections.

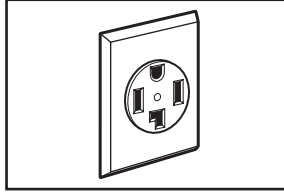

4-wire receptacle (NEMA type 14-30R)

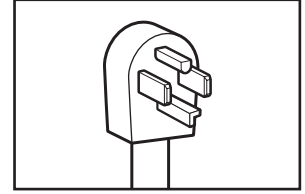

4-prong plug

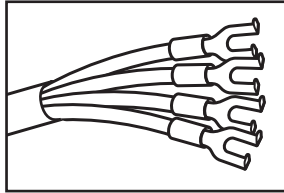

Spade terminals with upturned ends

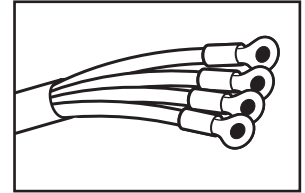

Ring terminals

### 1. Connect neutral ground wire and neutral wire

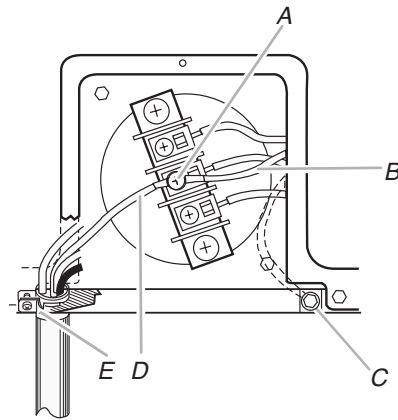

Remove center terminal block screw (A). Remove neutral ground wire (B) from external ground conductor screw (C). Connect neutral ground wire (B) and the neutral wire (D) (white or center wire) of power supply cord (E) under center, terminal block screw (A). Tighten screw.

### 2. Connect ground wire

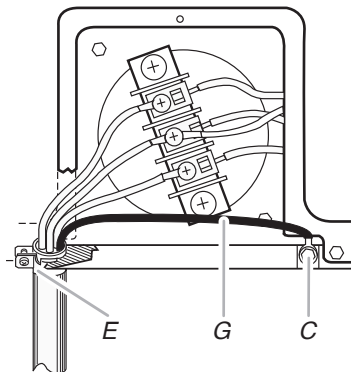

Connect ground wire (G) (green or bare) of power supply cord (E) to external ground conductor screw (C). Tighten screw.

3. Connect the other wires to outer terminal block screws. Tighten screws.
4. Tighten strain relief screws (E).
5. Insert tab of terminal block cover into slot of dryer rear panel. Secure cover with hold-down screw.
6. You have completed your electrical connection. Now go to "Venting Requirements."

### 3-Wire Power Supply Cord Connection

**IMPORTANT:** Use where local codes permit connecting cabinet-ground conductor to neutral wire.

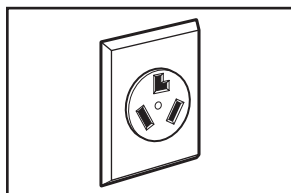

3-wire receptacle  
(NEMA type 10-30R)

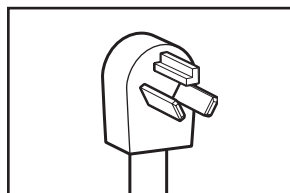

3-prong plug

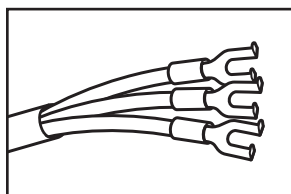

Spade terminals with  
upturned ends

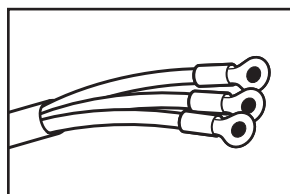

Ring terminals

### 1. Connect neutral wire

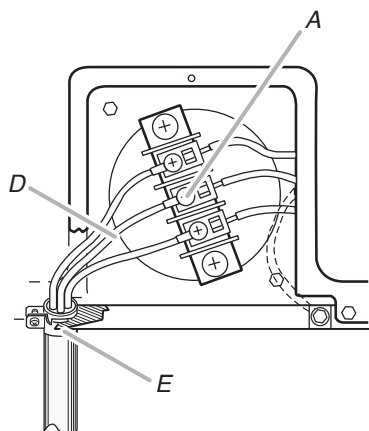

Remove center terminal block screw (A). Connect neutral wire (D) (white or center wire) of power supply cord (E) to the center terminal screw of the terminal block (A). Tighten screw.

2. Connect the other wires to outer terminal block screws. Tighten screws.
3. Tighten strain relief screws (E).
4. Insert tab of terminal block cover into slot of dryer rear panel. Secure cover with hold-down screw.
5. You have completed your electrical connection. Now go to "Venting Requirements."

## Direct Wire Connection

### Direct Wire Strain Relief

#### 1. Attach direct wire strain relief

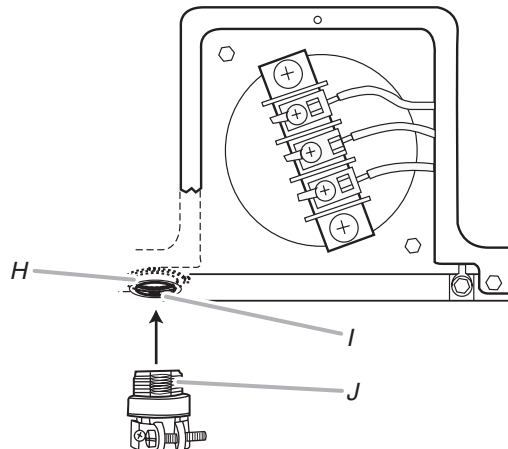

Unscrew the removable conduit connector (H) and any screws from a 3/4" (19 mm) UL listed strain relief (UL marking on strain relief). Put the threaded section of the strain relief (J) through the hole below the terminal block opening (I). Reaching inside the terminal block opening, screw the removable conduit connector (H) onto the strain relief threads.

#### 2. Attach direct wire cable to strain relief

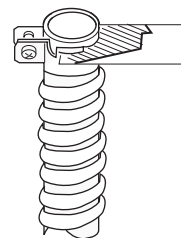

Put direct wire cable through the strain relief. The strain relief should have a tight fit with the dryer cabinet and be in a horizontal position. Tighten strain relief screw against the direct wire cable.

#### If your wiring looks like this:



4-wire direct connection:  
Go to "4-Wire Direct Connection" on page 13.



3-wire direct connection:  
Go to "3-Wire Direct Connection" on page 14.

## 4-Wire Direct Wire Connection

**IMPORTANT:** A 4-wire connection is required for mobile homes and where local codes do not permit 3-wire connections.

### 1. Prepare your 4-wire cable for direct connection

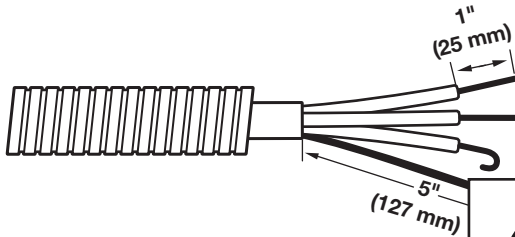

Direct wire cable must have 5 ft. (1.52 m) of extra length so washer/dryer may be moved if needed.

Strip 5" (127 mm) of outer covering from end of cable, leaving bare ground wire at 5" (127 mm). Cut 1½" (38 mm) from remaining 3 wires. Strip insulation back 1" (25 mm). Shape ends of wires into hooks.

When connecting to the terminal block, place the hooked end of the wire under the screw of the terminal block (hook facing right), squeeze hooked end together and tighten screw.

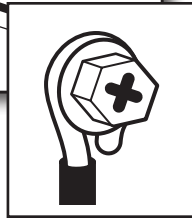

### 2. Connect neutral ground wire and neutral wire

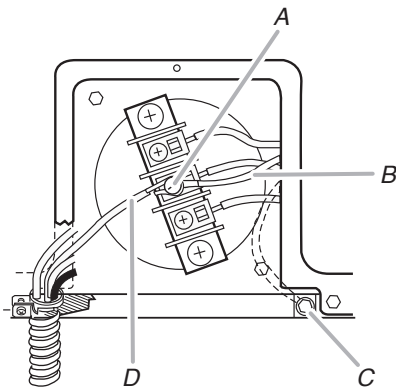

Remove center terminal block screw (A). Remove neutral ground wire (B) from external ground conductor screw (C). Connect neutral ground wire (B) and place the hooked end (hook facing right) of the neutral wire (D) (white or center wire) of direct wire cable under the center screw (A) of the terminal block. Squeeze hooked ends together. Tighten screw.

### 3. Connect ground wire

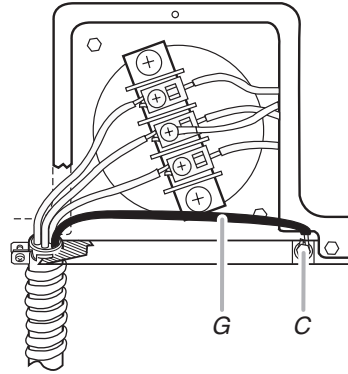

Connect ground wire (green or bare) (G) of direct wire cable to external ground conductor screw (C). Tighten screw.

### 4. Connect other wires

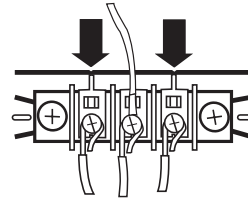

Place the hooked ends of the other power supply cable wires under the outer terminal block screws (hooks facing right). Squeeze hooked ends together. Tighten screws.

5. Tighten strain relief screw.

6. Insert tab of terminal block cover into slot of dryer rear panel. Secure cover with hold-down screw.

7. You have completed your electrical connection. Now go to "Venting Requirements."

### 3-Wire Direct Wire Connection

**IMPORTANT:** Use where local codes permit connecting cabinet-ground conductor to neutral wire.

#### 1. Prepare your 3-wire cable for direct connection

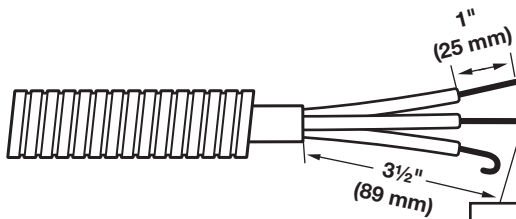

Direct wire cable must have 5 ft. (1.52 m) of extra length so washer/dryer may be moved if needed.

Strip 3 1/2" (89 mm) of outer covering from end of cable. Strip insulation back 1" (25 mm). If using 3-wire cable with ground wire, cut bare wire even with outer covering. Shape wire ends into hooks.

When connecting to the terminal block, place the hooked end of the wire under the screw of the terminal block (hook facing right), squeeze hooked end together and tighten screw

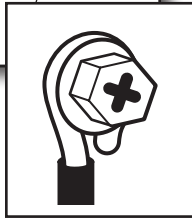

#### 2. Connect neutral wire

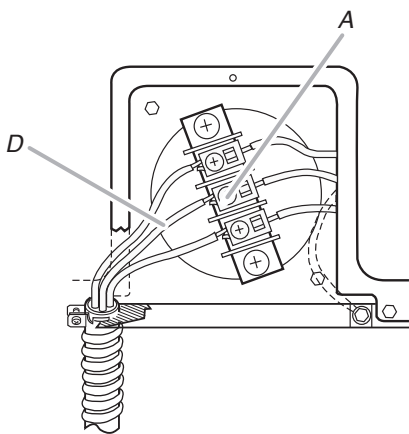

Remove center terminal block screw (A). Place the hooked end of the neutral wire (D) (white or center wire) of direct wire cable under the center screw of terminal block (A) (hook facing right). Squeeze hooked end together. Tighten screw

#### 3. Connect other wires

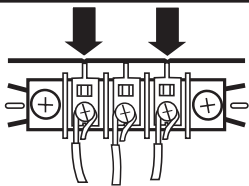

Place the hooked ends of the other power supply cable wires under the outer terminal block screws (hooks facing right). Squeeze hooked ends together. Tighten screws.

4. Tighten strain relief screw.
5. Insert tab of terminal block cover into slot of dryer rear panel. Secure cover with hold-down screw.
6. You have completed your electrical connection. Now go to "Venting Requirements."

### Optional 3-Wire Connection

**IMPORTANT:** You must verify with a qualified electrician that this grounding method is acceptable before connecting.

#### 1. Connect neutral ground wire and neutral wire

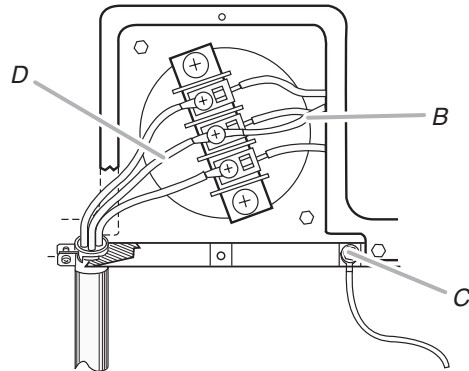

Remove center terminal block screw. Remove neutral ground wire (B) from external ground conductor screw (C). Connect neutral ground wire (B) and the neutral wire (D) (white or center wire) of power supply cord/cable under center, terminal block screw. Tighten screw.

#### 2. Connect other wires

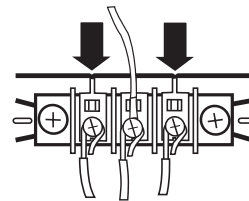

Connect the other wires to outer terminal block screws. Tighten screws.

3. Tighten strain relief screws.
4. Connect a separate copper ground wire from the external ground conductor screw to an adequate ground.
5. Insert tab of terminal block cover into slot of dryer rear panel. Secure cover with hold-down screw.



# VENTING

## Venting Requirements

### **! WARNING**



#### Fire Hazard

Use a heavy metal vent.

Do not use a plastic vent.

Do not use a metal foil vent.

Failure to follow these instructions can result in death or fire.

**WARNING:** To reduce the risk of fire, this dryer MUST BE EXHAUSTED OUTDOORS.

**IMPORTANT:** Observe all governing codes and ordinances.

Dryer exhaust must not be connected into any gas vent, chimney, wall, ceiling, attic, crawlspace, or a concealed space of a building. Only rigid or flexible metal vent shall be used for exhausting.

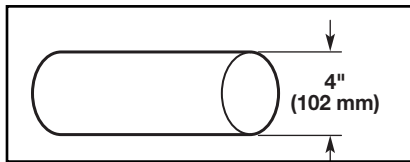

4" (102 mm) heavy metal exhaust vent

- Only a 4" (102 mm) heavy metal exhaust vent and clamps may be used.
- Do not use plastic or metal foil vent.

#### Rigid metal vent:

- Recommended for best drying performance and to avoid crushing and kinking.

#### Flexible metal vent: (Acceptable only if accessible to clean)

- Must be fully extended and supported in final dryer location.
- Remove excess to avoid sagging and kinking that may result in reduced airflow and poor performance.
- Do not install in enclosed walls, ceilings, or floors.
- The total length should not exceed 7<sup>3</sup>/<sub>4</sub> ft. (2.4 m).

**NOTE:** If using an existing vent system, clean lint from entire length of the system and make sure exhaust hood is not plugged with lint. Replace plastic or metal foil vents with rigid metal or flexible metal vents. Review "Vent System Chart" and, if necessary, modify existing vent system to achieve best drying performance.

#### Exhaust hoods:

- Must be at least 12" (305 mm) from ground or any object that may obstruct exhaust (such as flowers, rocks, bushes, or snow).

#### Recommended Styles:

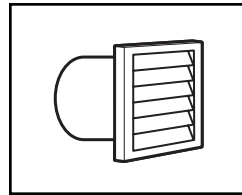

Louvered hood

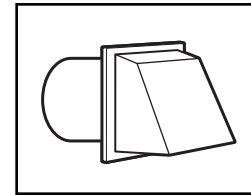

Box hood

#### Acceptable Style:

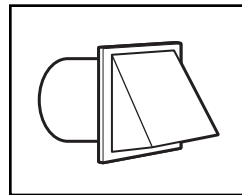

Angled hood

#### Elbows:

- 45° elbows provide better airflow than 90° elbows.

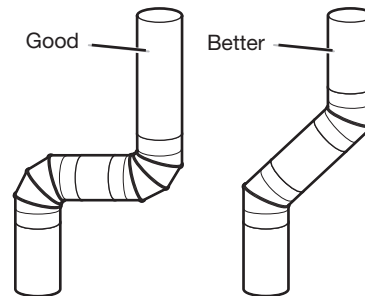

#### Clamps:

- Use clamps to seal all joints.
- Exhaust vent must not be connected or secured with screws or other fastening devices that extend into interior of duct and catch lint. Do not use duct tape.

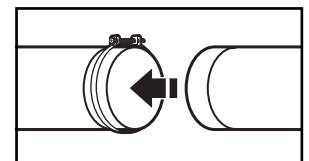
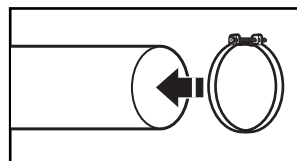

#### Improper venting can cause moisture and lint to collect indoors, which may result in:

- Moisture damage to woodwork, furniture, paint, wallpaper, carpets, etc.
- Housecleaning problems and health problems.

See "Venting Kits" for more information.



# Plan Vent System

## Recommended exhaust installations

Typical installations vent the washer/dryer from the rear. Other installations are possible.

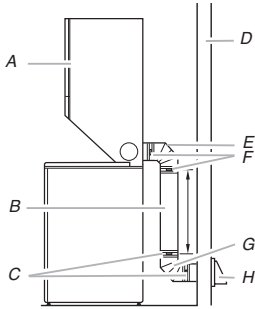

- A. Dryer
- B. Rigid metal or flexible metal vent
- C. Clamps
- D. Wall
- E. Elbow
- F. Clamps
- G. Elbow
- H. Exhaust hood

## Optional exhaust installations:

This washer/dryer can be converted to exhaust out the right or left side. To convert the washer/dryer, use Side Exhaust Kit Part Number 279823. If your washer/dryer was previously exhausted from the right or left side, it can be converted to rear exhaust by using standard offset plugs connections. To cover the hole in the side, one of the following plugs can be added:

- 692790 (white)
- 3979370 (graphite)
- 3977784 (biscuit)

Follow the instructions in the kit to install. Kits are available from the dealer from whom you purchased your washer/dryer.

## WARNING



### Fire Hazard

Cover unused exhaust holes with a manufacturer's exhaust cover kit.

Contact your local dealer.

Failure to follow these instructions can result in death, fire, electrical shock, or serious injury.

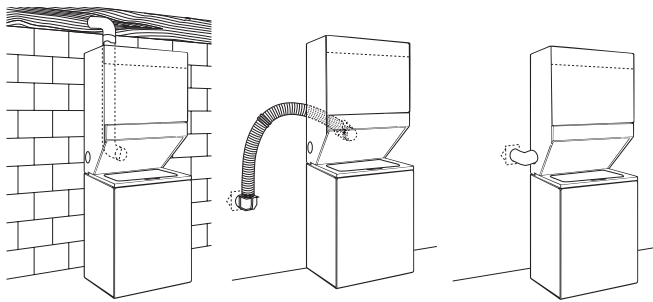

- A. Standard rear offset exhaust installation
- B. Rear exhaust for offset close-clearance connection
- C. Left- or right-side exhaust installation

## Alternate installations for close clearances

Venting systems come in many varieties. Select the type best for your installation. Three close-clearance installations are shown. Refer to the manufacturer's instructions.

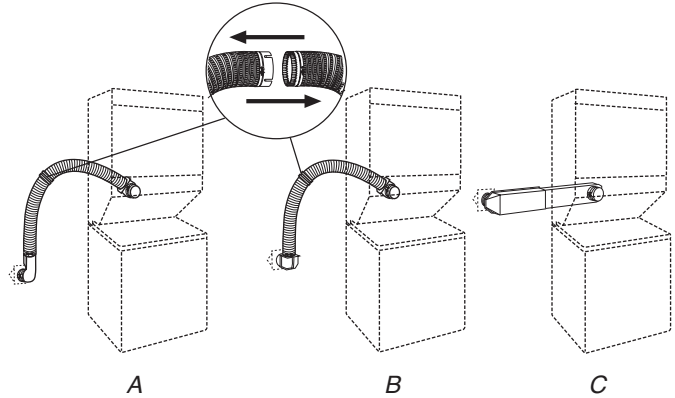

- A. Loop system with standard elbows
- B. Loop system with one offset and one standard elbow
- C. Vent system with one periscope (2" [51 mm] clearance)

**NOTE:** The following kits for close-clearance alternate installations are available for purchase.

## Venting Kits

For more information, call **1-800-901-2042**, or visit us at [www.applianceaccessories.com](http://www.applianceaccessories.com). In Canada, call **1-800-807-6777** or visit us at [www.whirlpoolparts.ca](http://www.whirlpoolparts.ca).

Part Number	Descriptions
4396028	Over-the-Top Installation
4396037	0" (0 mm) to 18" (457 mm) Metal vent periscope (For use with dryer vent to wall vent mismatch)
4396011	18" (457 mm) to 29" (737 mm) Metal vent periscope (For use with dryer vent to wall vent mismatch)
4396014	29" (737 mm) to 50" (1.27 m) Metal vent periscope (For use with dryer vent to wall vent mismatch)
4392892	In-Wall metal DuraVent™ Periscope
279818	4-way vent kit – white
W10186596	4-way vent kit – universal grey
4396028	Sure Connect™ venting kit (over-the-top installation)
4396009RP	5' Universal connect vent, flexible dryer venting
4396010RP	6' SecureConnect™ vent, flexible dryer venting
4396013RB	Dryer vent installer's kit
4396033RP	5' flexible dryer venting with clamps
4396727RP	8' flexible dryer venting with clamps
4396004	Dryer offset elbow
4396005	Wall offset elbow
4396006RW	DuraSafe™ close elbow
4396007RW	Through-the-wall vent cap
4396008RP	4" steel dryer venting clamps – 2 pack
8212662	Flush mounting louvered vent hood 4"

**Special provisions for mobile home installations:**

The exhaust vent must be securely fastened to a noncombustible portion of the mobile home structure and must not terminate beneath the mobile home. Terminate the exhaust vent outside.

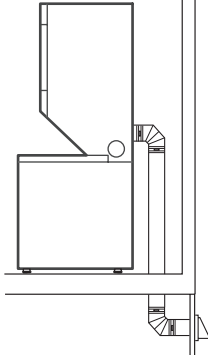

**Determine vent path:**

- Select route that will provide straightest and most direct path outdoors.
- Plan installation to use fewest number of elbows and turns.
- When using elbows or making turns, allow as much room as possible.
- Bend vent gradually to avoid kinking.
- Use as few 90° turns as possible.

**Determine vent length and elbows needed for best drying performance:**

- Use following “Vent System Chart” to determine type of vent material and hood combinations acceptable to use.

**NOTE:** Do not use vent runs longer than those specified in “Vent System Chart.” Exhaust systems longer than those specified will:

- Shorten life of dryer.
- Reduce performance, resulting in longer drying times and increased energy usage.

The “Vent System Chart” provides venting requirements that will help achieve best drying performance.

Vent System Chart			
Number of 90° turns or elbows	Type of vent	Box/louvered hoods	Angled hoods
0	Rigid metal	43 ft. (13.1 m)	36 ft. (11.0 m)
1	Rigid metal	33 ft. (10.1 m)	26 ft. (7.9 m)
2	Rigid metal	24 ft. (7.3 m)	16 ft. (4.9 m)

**NOTE:** Side exhaust installations have a 90° turn inside the dryer. To determine maximum exhaust length, add one 90° turn to the chart.

# INSTALL VENT SYSTEM

## 1. Install exhaust hood

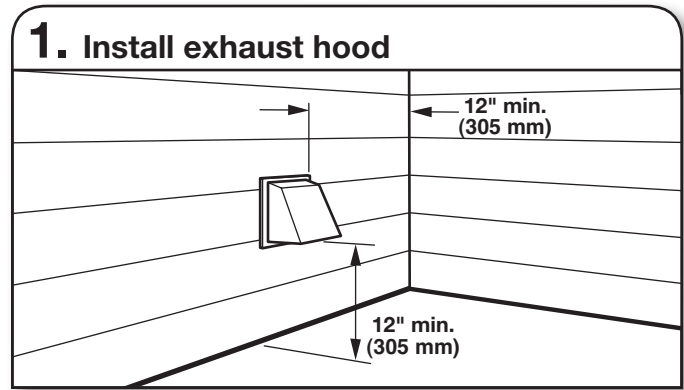

Install exhaust hood and use caulking compound to seal exterior wall opening around exhaust hood.

## 2. Connect vent to exhaust hood

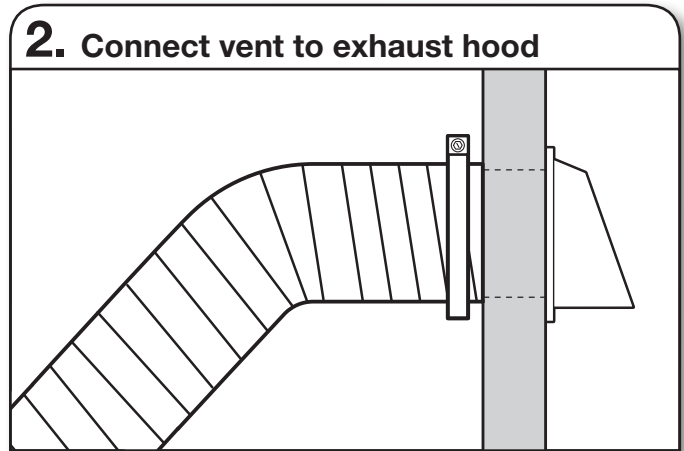

Vent must fit over the exhaust hood. Secure vent to exhaust hood with 4" (102 mm) clamp. Run vent to dryer location using straightest path possible. Avoid 90° turns. Use clamps to seal all joints. Do not use duct tape, screws, or other fastening devices that extend into interior of vent to secure vent, because they can catch lint.

# CONNECT DRAIN HOSE

Proper connection of the drain hose protects your floors from damage due to water leakage. To keep the drain hose from coming off or leaking, it must be installed according to the following instructions:

**IMPORTANT:** To ensure proper installation, this procedure must be followed exactly.

## 1. Attach clamp to drain hose

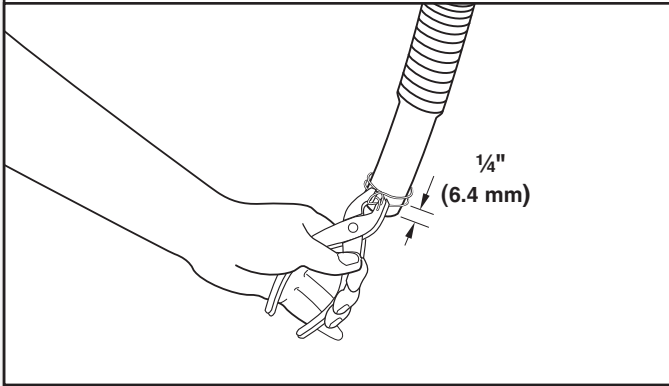

Check the drain hose to see whether it is the proper length. Wet the inside of the straight end of the drain hose with tap water.

**IMPORTANT:** Do not use any lubricant other than water.

Squeeze ears of the silver double-wire clamp with pliers to open. Place clamp over the straight end of the drain hose 1/4" (6.4 mm) from the end.

## 2. Attach drain hose to drain connector

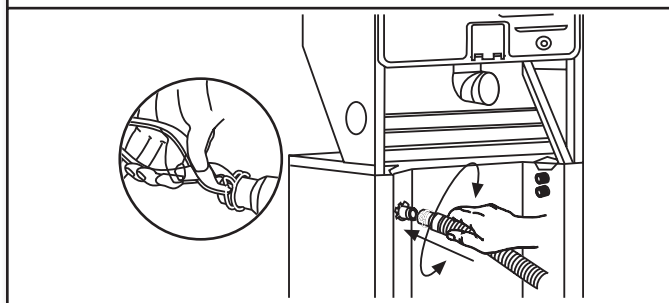

Open clamp. Twist hose back and forth while pushing onto drain connector on the side of the washer/dryer. Continue until hose contacts the ribbed stops on the cabinet. Place clamp over the area marked "CLAMP." Release clamp.

## 3. Place drain hose in standpipe

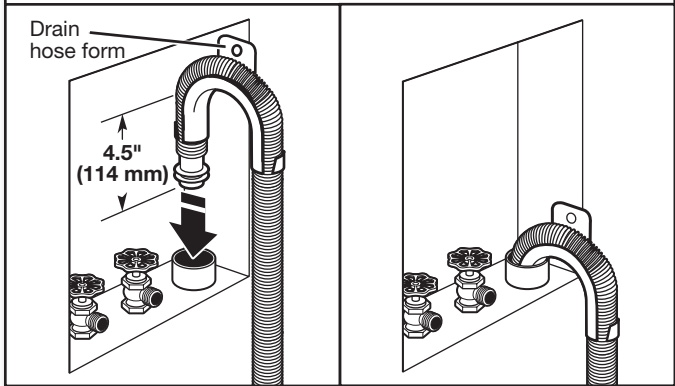

Place hose into standpipe (shown in picture) or over side of laundry tub.

**IMPORTANT:** 4.5" (114 mm) of drain hose should be inside standpipe; do not force excess hose into standpipe or lay on bottom of laundry tub. Drain hose form must be used.

## 4. Remove drain hose form (floor drain installations only)

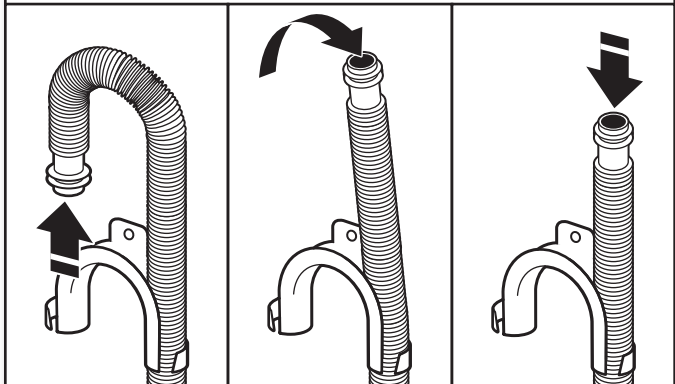

For floor drain installations, you will need to remove the drain hose form from the end of the drain hose. You may need additional parts with separate directions. See "Tools and Parts."

# CONNECT INLET HOSES

Washer must be connected to water faucets with new inlet hoses with flat washers. Do not use old hoses.

**NOTE:** Both hoses must be attached and have water flowing to inlet valves. If you are only connecting to a cold water faucet, you must use a Y-adapter (not included).

## 1. Insert washer into each hose

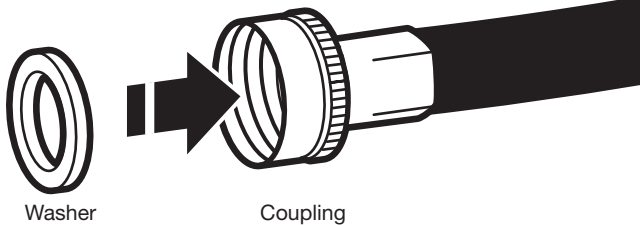

Insert a new flat washer into each end of the inlet hoses. Firmly seat the washers in the couplings.

## 2. Connect inlet hoses to water faucets

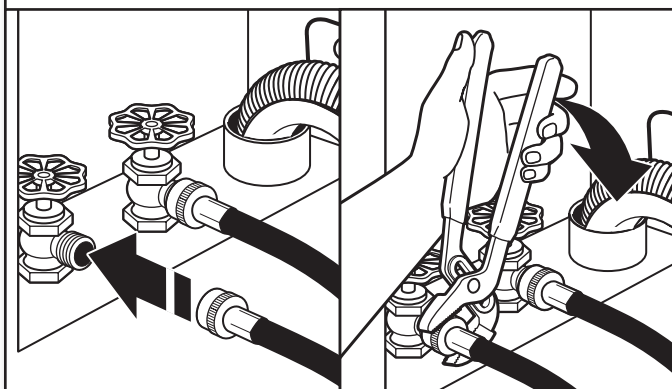

Attach hose to hot water faucet. Screw on coupling by hand until it is seated on washer. Use pliers to tighten couplings an additional two-thirds turn. Repeat this step with second hose for cold water faucet.

**IMPORTANT:** Do not overtighten or use tape or sealants on valve when attaching to faucets or washer. Damage can result.

**HELPFUL TIP:** Make note of which hose is connected to hot water to help in attaching hoses to washer correctly. In most standard configurations, hoses will cross over each other when attached correctly.

## 3. Clear water lines



Run water for a few seconds through hoses into a laundry tub, drainpipe, or bucket to prevent clogs. Water should run until clear.

## 4. Connect inlet hoses to washer

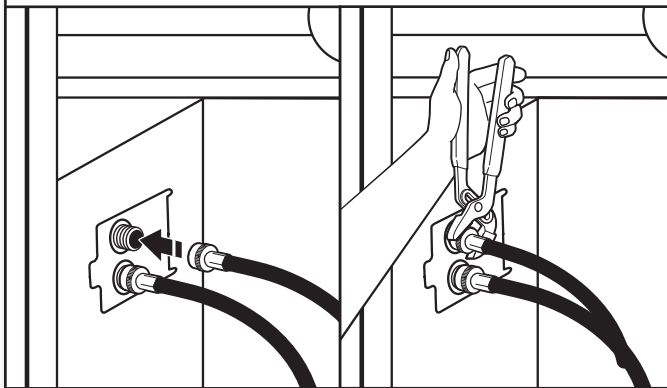

Attach hot water hose to the bottom inlet valve. Screw coupling by hand until it is snug. Use pliers to tighten couplings an additional two-thirds turn. Repeat with cold water inlet valve (top valve).

**IMPORTANT:** To reduce risk of hose failure, replace the hoses every 5 years. Record hose installation or replacement dates for future reference.

- Periodically inspect and replace hoses if bulges, kinks, cuts, wear, or leaks are found.

## 5. Move washer/dryer to final location

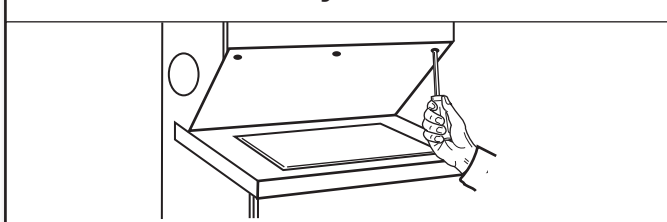

If you are working in a closet or recessed area: move the washer/dryer into its final location and remove cardboard from under washer/dryer. Remove the access panel by removing 3 Phillips-head screws and one bumper, located at the top of the access panel. Set panel, screws, and bumper aside. Complete hookup of water hoses and vent. Replace access panel upon completion of washer/dryer installation.

## CONNECT INLET HOSES

### 6. Check for leaks

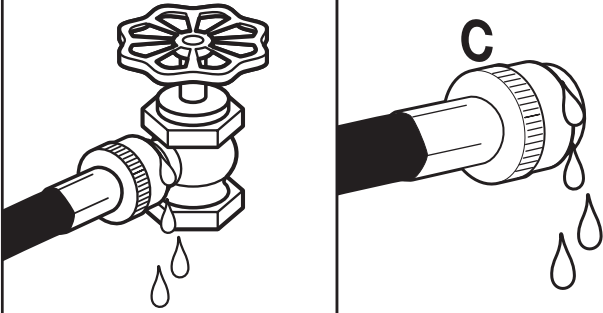

Turn on water faucets to check for leaks. A small amount of water may enter washer. It will drain later.

### 7. Secure drain hose

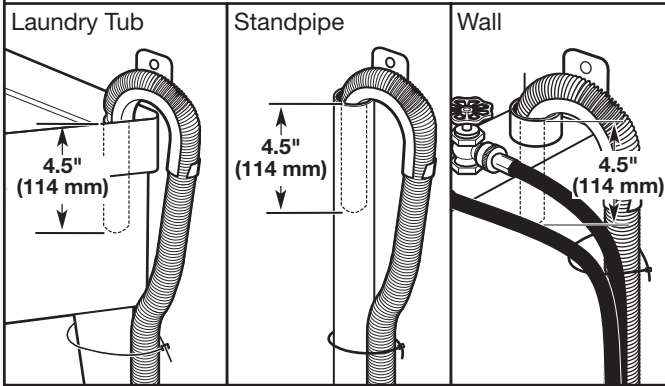

Secure drain hose to laundry tub leg, drain standpipe, or inlet hoses for wall standpipe with tie strap (included in parts package).

## CONNECT VENT

### 1. Connect vent to exhaust outlet

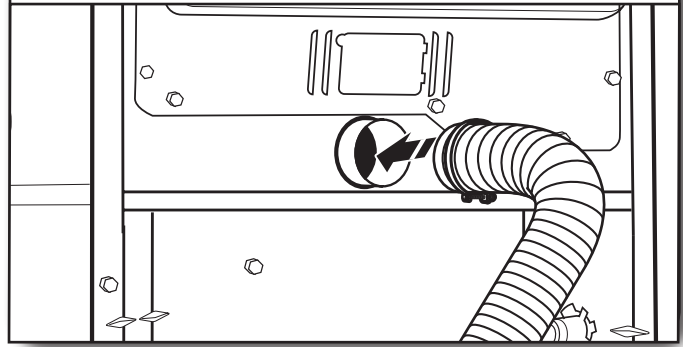

Using a 4" (102 mm) clamp, connect vent to exhaust outlet in dryer. If connecting to existing vent, make sure vent is clean. Dryer vent must fit over dryer exhaust outlet and inside exhaust hood. Check that vent is secured to exhaust hood with a 4" (102 mm) clamp.

### 2. Move washer/dryer to final location

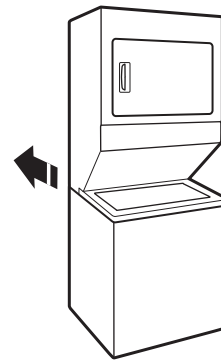

Move washer/dryer to final location, taking care not to crush or kink vent.

After washer/dryer is in place, remove corner posts and cardboard from under washer/dryer.

# LEVEL WASHER/DRYER

**IMPORTANT:** Level washer/dryer properly to reduce excess noise and vibration.

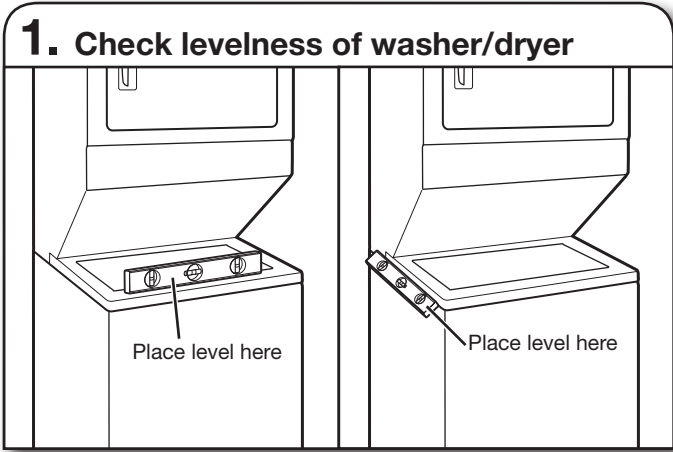

With washer/dryer in its final location, place a level on top edges of washer/dryer. Use side seam as a guide to check levelness of sides. Check levelness of front using lid, as shown. Rock washer/dryer back and forth to make sure all four legs make solid contact with floor.

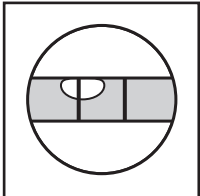

Not Level

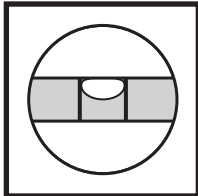

LEVEL

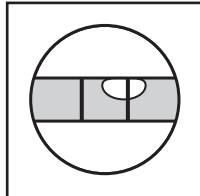

Not Level

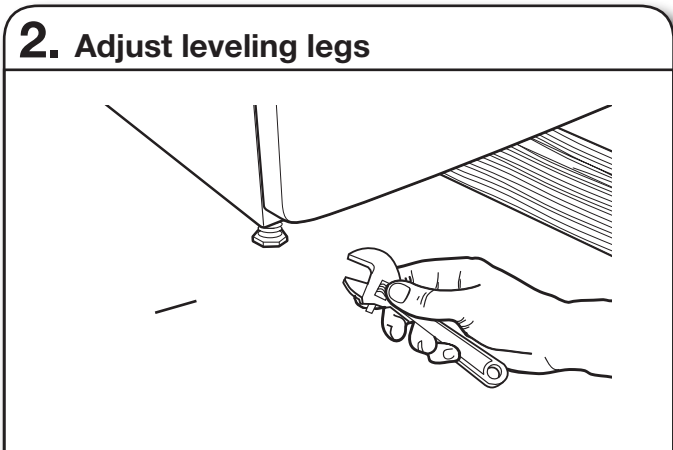

If washer/dryer is not level, use a 1" or 25 mm open-end or adjustable wrench to turn the leveling legs counterclockwise to lower the washer/dryer or clockwise to raise the washer/dryer. Recheck levelness of washer/dryer and repeat as needed.

**HELPFUL TIP:** You may want to prop up front of washer/dryer about 4" (102 mm) with a wood block or similar object that will support weight of washer/dryer.

## ⚠ WARNING

**Electrical Shock Hazard**

- Plug into a grounded 3 or 4 prong outlet.
- Do not remove ground prong.
- Do not use an adapter.
- Do not use an extension cord.

Failure to follow these instructions can result in death, fire, or electrical shock.

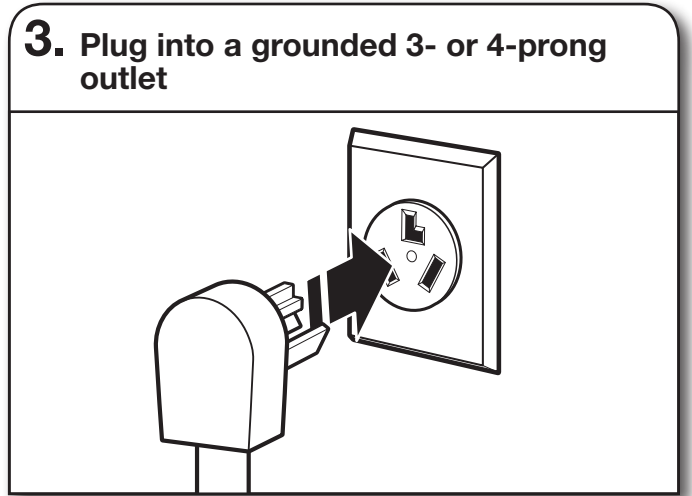

# COMPLETE INSTALLATION CHECKLIST

- Check that all parts are now installed. If there is an extra part, go back through the steps to see which step was skipped.
- Check that you have all of your tools.
- Dispose of/recycle all packaging materials. Keep the plastic foam for use if the washer/dryer should be transported.
- Check the washer/dryer's final location. Be sure the vent is not crushed or kinked.
- Check that the washer/dryer is level and front leveling feet are tight. See "Level Washer/Dryer."
- For power supply cord installation, plug into a grounded outlet. For direct wire installation, turn on power.
- Check that the water faucets are on.
- Check for leaks around faucets and inlet hoses.
- Remove the blue protective film on the console and any tape remaining on the washer/dryer.
- Read the Washer/Dryer Use and Care Guide.
- Wipe the dryer drum interior thoroughly with a damp cloth to remove any dust.
- To test the washer, measure 1/2 the normal recommended amount of detergent and pour it into the washer. Close the lid. Select REGULAR and pull out the Cycle Control knob. Allow the washer to complete one whole cycle.
- To test the dryer, set the dryer on a full heat cycle (not an air cycle) for 20 minutes and start the dryer.
  - If the dryer will not start, check the following:**
    - Controls are set in a running or "On" position.
    - START button has been firmly pushed.
    - Washer/dryer is plugged into a grounded outlet.
    - Electrical supply is connected.
    - Household fuses are intact and tight, or circuit breakers have not tripped.
    - Dryer door is closed.
  - When the dryer has been running for 5 minutes, open the dryer door and feel for heat.
    - If you do not feel heat, turn off the dryer and check the following:**
      - There may be 2 household fuses or circuit breakers for the dryer. Check that both fuses are intact and tight, or that both circuit breakers have not tripped. If there is still no heat, contact a qualified technician.

**NOTE:** You may notice an odor when dryer is first heated. This odor is common when the heating element is first used. The odor will go away.



# NOTES

